

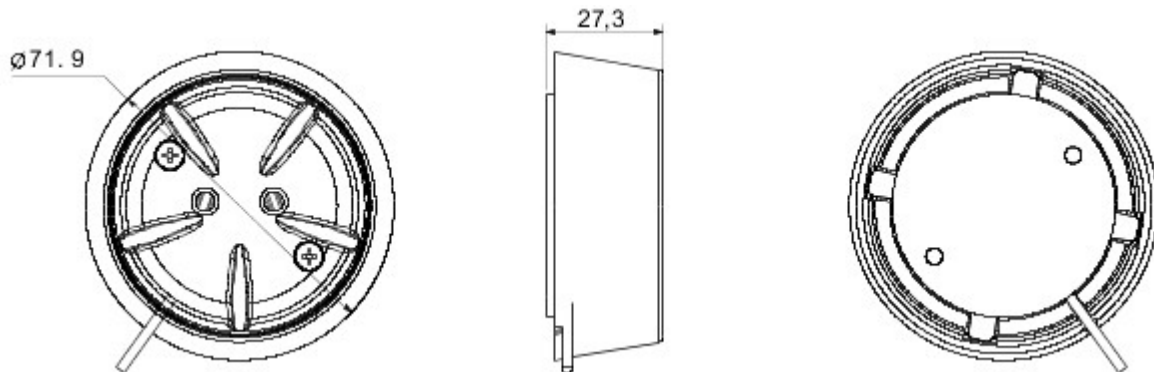

Surface mounting accessory for a GWA connected water sensor1514.

Categorie	Accessory for flood sensor surface mounting	Culoare	Alb
Material	Tehnopolimer	Standard	2014/53/EU
Clasă de protecție IP	IP20	Temperatură de funcționare	0 ÷ +50 °C
Temperatură de stocare	-20 ÷ +80 °C	Relative humidity (non-condensative)	10 ÷ 95%
Suport suport (mm)	Ø72x25	Dimensions of probe (mm)	Ø50x8
Cable max. length (cm)	85	Electrocod	051A

DIMENSIONAL



TECHNICAL SYMBOLOGY

IP

IP20

STANDARDS/APPROVALS

**UK
CA** **CE**